

Model SPVRA

Three Phase Voltage Monitor

Standard Features

- Phase Unbalance: 8 %
- Adjustable Trip Delay 1 to 10 seconds after failure occurs.
- Output Relay: normally de-energized: Form C contacts for easy circuit configuration.
- Electro - Mechanical Indicator: retains memory of fault until manually reset.
- Door or Panel mounting.
- Status Indicator: bi-colored LED Green: Output Relay De-energized (Normal Condition) Red: Output Relay Energized (Fault Condition) Dark: Output relay De energized (Input Power Off).
- Single Phase, Phase Reversal, Phase Unbalance and Phase Loss Protection: Operates the output relay after a preselected time.
- Overvoltage and Undervoltage Protection: Operates when voltage exceeds 115 % or goes below 80 % after a preselected time.
- Automatic or Manual - Automatic Reset to Normal: upon removal of fault conditions. Manual Reset: Operations from a local pushbutton in cover or from a remote contact.

The Model SPVRA Voltage Sensing Relay is designed to protect against single phase, phase loss, phase unbalance, phase reversal, and under or over voltage in a power system. The output contacts change their normal state only when a phase loss, phase unbalance, phase reversal, under or overvoltage occurs for longer than the preset trip delay. A total power loss de-energization of the SPVRA relay will not change the output contact position. Recommended for manually reset switches and breakers applications. The SPVRA is suitable for loss of phase with motor loads.

Application

Protection of three phase electric equipment sensitive to damage from a phase loss or phase unbalance. Phase reversal, phase sequence, undervoltage & overvoltage protection.

Normal Input Voltages

120 to 600 Vac, 60 Hz., 380 to 415 Vac, 50 Hz.

Ambient Temperature Range

Operation: - 30 °C to +60 °C.

Storage - 40 °C to + 85 °C.

Terminals screws are #6-32 nickel plated brass.

Shipping weight 2.0 lbs

SPVRA Models

Model Number	Nominal Vac	Hz.
SPVRA-120	120	60
SPVRA-208	208	60
SPVRA-240	240	60
SPVRA-480	480	60
SPVRA-575	575	60
SPVRA-380	380	50
SPVRA-415	415	50

SPVRA Typical Wiring Diagram

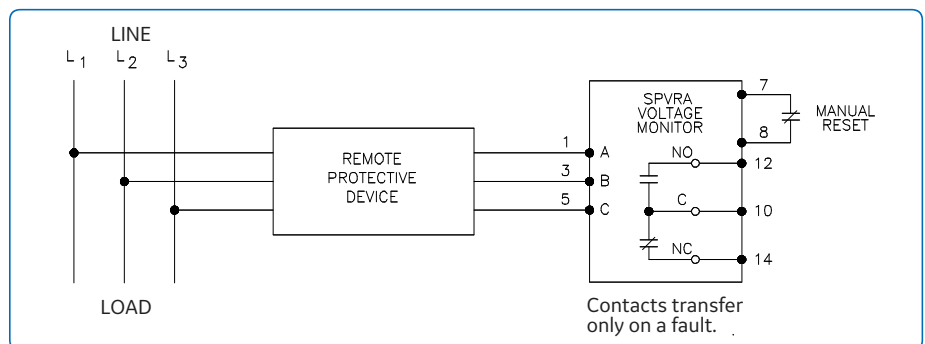

REGULATORY AGENCY APPROVALS



103039, CANADIAN



103039

Contact Rating

10 A, 1/3 H.P. AT 120 VAC
10 A, 1/2 H.P. AT 240 VAC
3 A, 1/2 H.P. AT 600 VAC

How to Order Relays

SPVRA - XXX

Input Voltage
120, 208, 240, or 575Vac (60 Hz)
380 or 415Vac (50 Hz)



SPVRA Dimensions

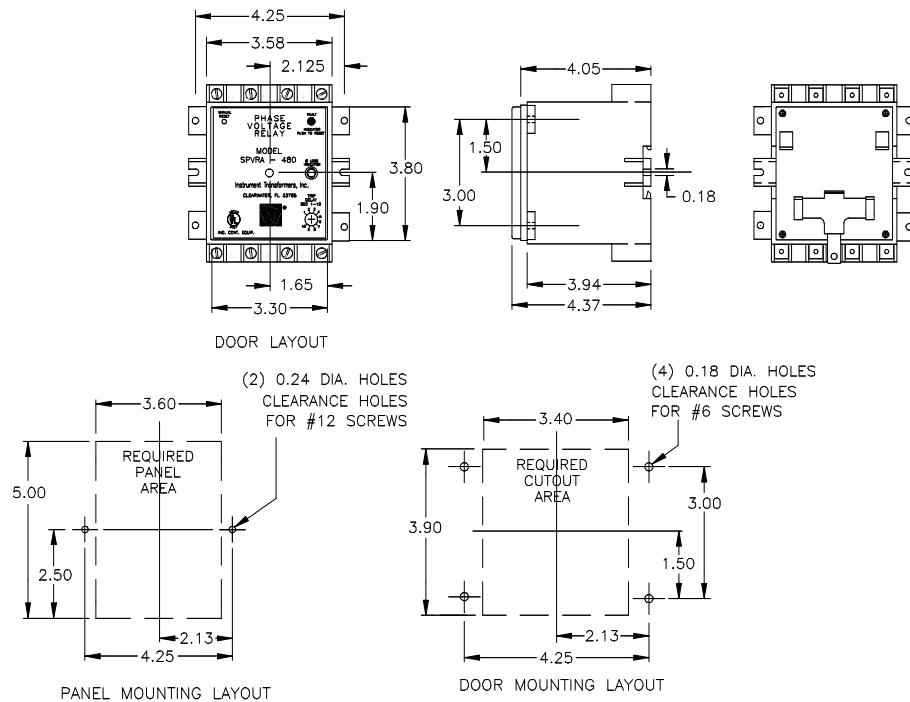

SPVRA Operation with Options

A correctly installed SPVRA Voltage Sensing Relay will protect a power system against damage due to single phase and phase loss, phase reversal, phase unbalance, and under and over voltage. When operating under normal power conditions, the bi-colored LED Relay Status will be green indicating the de-energized state of the output relay.

If a single phase, phase sequence, phase reversal, phase loss or unbalance of 8 % occurs for longer than the preselected time delay of 1 to 10 seconds, the output relay is energized and changes state. If the voltage level dips below 80 % but is above 60 % after the preselected time, or if the voltage exceeds 115 % for a preselected time the the output relay changes state. This output relay returns to its normal de-energized state when undervoltage returns to 90% or the overvoltage reduces to 107 %. Whenever the output relay contacts are energized indicating a fault, the bi-colored LED "Relay Status" will be red.

With the manual reset, a local reset push-button is provided on the front of the relay. Two terminals provide can be used for a normally close remote reset button. When the main power is restored, the output relay is energized immediately if a reset button has not been operated.

The output relay has single Form C contact.

The SPVRA relay is package is in a high impact thermoplastic enclosed which can be either panel or door mounted. The terminal hardware is set for panel or door mounted. The terminal hardware is set for panel mounting but is easily reversed for door mounting. A clear cover is provided to prevent accidental mechanical indicator changes.

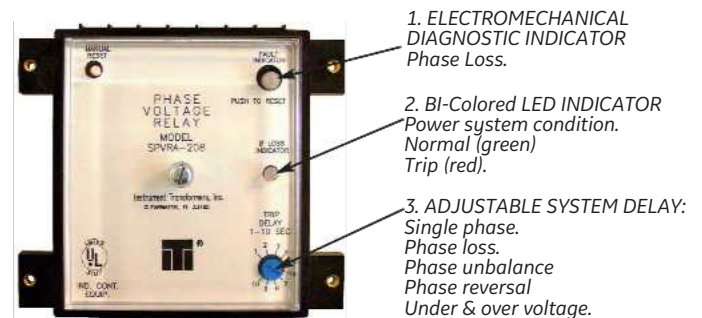

Grid-AIS-L4-ITL_Model_SPVRA-1582-2017_08-EN. © Copyright 2017. General Electric Company and Instrument Transformers LLC reserve the right to change specifications of described products at any time without notice and without obligation to notify any person of such changes.

